

## Design of a Water Jet Using a Robin Engine as the Propulsion System for a 1 GT Boat

Muhammad Ikhsan<sup>1</sup>, Siswandi B<sup>1</sup>, Jupri<sup>1</sup>, Efrizal<sup>1</sup>, Muhammad Riyan Saputra<sup>1</sup>, Bima Kurniawan<sup>1</sup>,

<sup>1</sup>Department of Naval Architecture, Bengkalis State Polytechnic, Indonesian  
ikhsan@polbeng.ac.id<sup>1</sup>, siswandi@polbeng.ac.id<sup>2</sup>, jupri@polbeng.ac.id<sup>3</sup>,  
efrizal@polbeng.ac.id<sup>4</sup>

### Abstract

*The ship propulsion system functions to generate thrust that moves the vessel through the water. The water jet system is a type of propulsion that operates by drawing water from beneath the hull and expelling it through a nozzle, thereby producing thrust for the boat. The water jet design for a 1 GT boat consists of an intake body, nozzle, and a three-blade impeller with a diameter of 4 inches. The purpose of this design is to determine the performance of the water jet on a 1 GT boat. Based on direct testing, the boat achieved a speed of approximately 4–5 knots. The results of this test can serve as a basis for the application of the water jet system as an alternative propulsion method, particularly for 1 GT fishing boats operating in coastal waters.*

*Keywords: Boat, water jet, nozzle, impeller, speed*

### 1. INTRODUCTION

Small boats with a weight of 1 Gross Ton (GT) are one of the main modes of transportation used by fishermen and coastal communities in their daily economic activities. To support operational efficiency and navigational safety, the ship's propulsion system is a crucial component that must be carefully and accurately designed.



**Figure 1.** 1 GT Boat

In general, small boats still use conventional propulsion systems in the form of propellers driven by Robin engines, which have several limitations—especially when operated in shallow waters. The risks of damage due to collisions with underwater objects, limited maneuverability, and operational safety concerns are major issues. Therefore, it is necessary to study alternative propulsion systems that are more efficient, safer, and suitable for shallow-water operations.

One potential alternative propulsion technology is to replace the propeller with a water jet system powered by a Robin engine. This system operates on the principle of drawing water through an intake located beneath the hull and expelling it through a nozzle to generate thrust. The water jet offers advantages in terms of maneuverability, safety (as it has no exposed propeller), and efficiency at medium to high speeds.

Based on the considerations described above, this study aims to design a water jet propulsion system that matches the characteristics of a 1 GT boat and uses a Robin engine as

the power source. The goal is to provide an alternative propulsion solution that is safe, efficient, and practical.

## 2. REVIEW OF LITERATURE

### 2.1. Ship Propulsion System

The ship propulsion system functions to generate thrust that moves the vessel through water. The main components of a propulsion system include the power source (usually a diesel or gasoline engine), transmission, and the final drive mechanism (such as a propeller or water jet). The propulsion system must be designed in accordance with the vessel's size, function, and operational characteristics.

In small boats, the most commonly used propulsion system is the propeller. However, under certain conditions—such as shallow waters or areas with dense aquatic vegetation—propellers have disadvantages, including a higher risk of entanglement and damage. Therefore, alternative propulsion systems like water jets become an attractive option.



Figure 2. Ship Propulsion

### 2.2. Water Jet Propulsion System

The water jet system is a propulsion mechanism that operates by drawing water from beneath the hull and expelling it through a nozzle at the rear of the boat. The main components of this system are:

- Intake: The channel through which water enters the system.
- Impeller: A fan or enclosed propeller that accelerates water at high speed within the channel.
- Diffuser: Expands the channel diameter to reduce water velocity and increase pressure.
- Nozzle: Directs and accelerates the outgoing water flow to generate thrust.

The advantages of this system include:

- No exposed rotating parts like a propeller → safer.
- Effective in shallow and muddy waters.
- Higher maneuverability.

The thrust generated by a water jet propulsion system is caused by the increase in momentum of the water flow from the inlet channel to the nozzle outlet. Suction at the inlet creates friction with the hull surface, producing a certain flow velocity at the inlet. The thrust produced by the water jet system can be calculated using the following formula:

$$T = \rho A V_j (V_j - V_i) \quad (1)$$

Where:

T = Thrust

$\rho$  = Fluid density

$A$  = Nozzle cross-sectional area  
 $V_j$  = Nozzle outlet velocity  
 $V_i$  = Nozzle inlet velocity

The operation of a water jet system on a boat heavily depends on the pumping and high-speed ejection of water through the nozzle. Newton's law of action and reaction causes the boat to move forward as water is expelled backward. The impeller in this system functions to maximize the thrust produced by the water ejection, making the water jet system effective for faster and more efficient maneuvering in shallow waters.

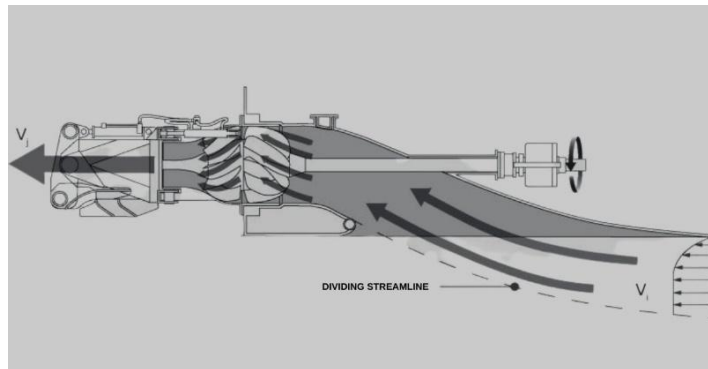

**Figure 3.** Water Jet Propulsion Flow

### 2.3. Robin Engine

The Robin engine is a single-cylinder diesel engine commonly used in small fishing boats. Its advantages include easy operation, readily available spare parts, and low maintenance costs. The engine has torque characteristics suitable for constant-load applications, such as driving pumps or propulsion systems.



**Figure 4.** Robin Engine

General Specifications of the Robin Engine:

- Output power: approximately 10–12 HP
- Maximum speed:  $\pm$  2400–2600 rpm
- Cooling system: air or water
- Fuel system: Peralite gasoline

### 3. METHOD

The design process of a water jet system for a 1 GT (Gross Tonnage) boat is carried out in the following steps:

a. Preliminary Study and Data Collection

The first step is to understand the requirements and conditions of the boat:

- The design is intended for a 1 GT fishing boat.
- Key boat data: length (L), width (B), draft (T), total weight, and desired engine power.
- Performance requirements: target boat speed.
- Operating environment: shallow sea, river, or open waters.

b. Power and Propulsion Requirements Analysis

This stage determines the required engine power:

- Determination of effective power.

c. Conceptual Design of the Water Jet System

Defining the main structure and operating principle of the system:

- Intake: designed to ensure stable water flow without cavitation.
- Impeller and housing: sized according to flow velocity, engine rotation, and water discharge.
- Nozzle outlet: determines the direction and speed of the water jet, which affects thrust.
- Steering & reversing mechanism: enables boat maneuvering.

d. Detailed Component Design

Each part of the water jet is designed with precise technical parameters:

- Water flow rate (Q): calculated from thrust and jet velocity.
- Selection of impeller and nozzle diameters.
- Impeller blade design with 3 blades.
- Materials used: stainless steel and composites.
- Integration with engine: design of the coupling and connecting shaft.

e. 3D Modeling

- Convert the design into a CAD model.

f. Prototype Fabrication and Testing

- Build a full-scale or test model prototype of the water jet.

g. Integration with the 1 GT Boat

- Install the water jet system onto the prepared hull.
- Conduct sea trials:
  - Speed testing
  - Performance evaluation

## 4. RESULT & DISCUSSION

### Data of 1 GT Fishing Boat

Fishing boats are the primary means for coastal communities to carry out fishing activities at sea. A 1 GT fishing boat is a small type of vessel with a gross weight of around 1 Gross Tonnage, generally used by traditional fishermen to catch fish in coastal waters. Its size is relatively small, usually 6–9 meters in length and 1.5–2 meters in width. The data and specifications of the boat used as the research object can be seen in Table 1.

**Table 1.** Specifications of the Fishing Boat

Parameter	Value	Unit
Length	6	m
Width	1,2	m
Height	0,6	m
Engine Power	7	Hp
Boat Speed	5	Knot

The design model of the 1 GT fishing boat can be seen in Figure 5.

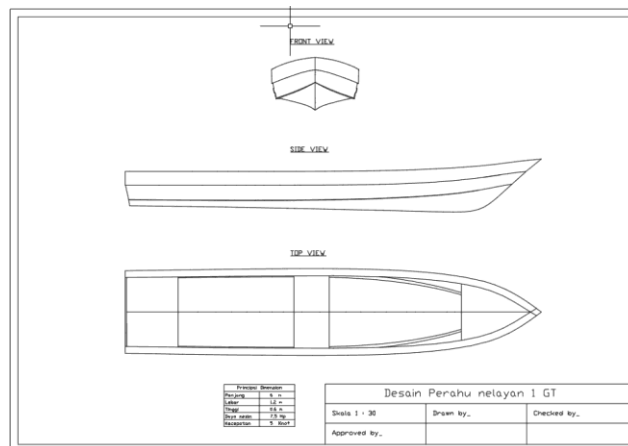

**Figure 5.** Design Model of 1 GT Fishing Boat

The fishing boat, after being constructed using fiberglass material, can be seen in Figure 6.

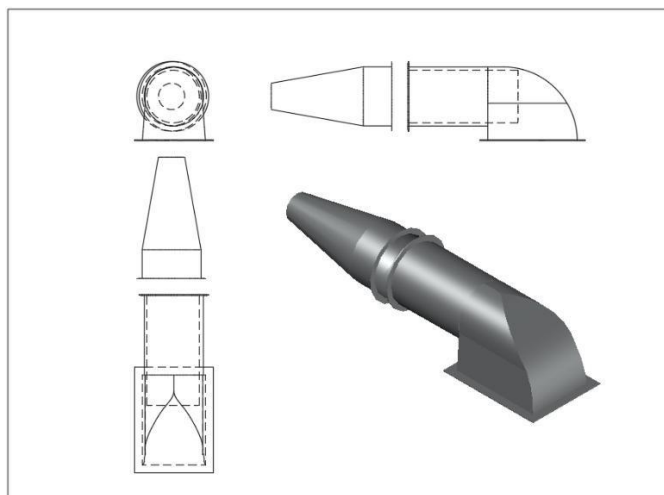

**Figure 6.** Shape of the 1 GT Fishing Boat

### Water Jet Design

The initial stage in designing a water jet propulsion system begins with identifying the operational requirements of the boat. This includes the type of vessel to be used; in this case, a 1 GT fishing boat with a conventional propulsion system powered by a 7 HP engine, achieving a speed of 5 knots. The operating waters are primarily near the coast or in shallow areas. These data serve as the basis for determining the water jet capacity, including the size of the pump (impeller), inlet duct, and discharge nozzle.

The fabrication process of the water jet propulsion system components starts with technical design planning based on the boat's specifications. From this design, each main component—such as the inlet duct, impeller, nozzle, steering nozzle, and reversing bucket—is translated into technical drawings and 3D models to facilitate fabrication. The design model of the water jet components can be seen in Figure 7.



**Figure 7.** Design of the Water Jet Intake Body and Nozzle

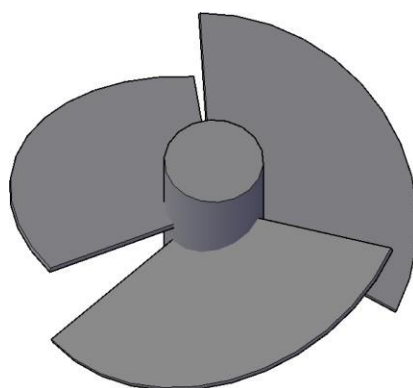

**Figure 8.** Design of the Water Jet Impeller

The dimensions or sizes of the water jet components can be seen in Table 2.

**Table 2.** Water Jet Dimensions

Parameter	Value	Unit
Impeller Diameter	4	inch
Number of Impeller Blades	3	blades
Inlet Duct Diameter	4	inch
Nozzle Diameter	2.5	inch
Pipe Diameter	4	inch

### Testing of the Water Jet Propulsion System

The water jet propulsion system for the 1 GT boat was tested to evaluate its performance, efficiency, and thrust characteristics. This propulsion system works by drawing water from beneath the hull using an impeller and then ejecting it backward through a high-velocity nozzle, generating thrust that propels the boat.

The testing was conducted to analyze the relationship between engine power, hydrodynamic efficiency, and effective thrust. In general, the water jet system offers advantages in terms of more responsive maneuvering and safety in shallow waters (due to the absence of exposed propellers).

The main objective of this test was to:

- Measure the maximum speed of the boat achievable with this water jet configuration.

The following is the documentation of the water jet testing on a 1 GT boat using an engine with a power output of 7 HP.



**Figure 9.** Water Jet Testing on a 1 GT Boat

The water jet test on the 1 GT boat was carried out four times over a trial distance of 100 meters. The test results are shown in Table 3 below.

**Table 3.** Water Jet Testing Results

Trial	Speed	Unit
1	4.6	knot
2	4.4	knot
3	5.3	knot
4	5.2	knot

From Table 3, it can be seen that the results of the water jet testing on the 1 GT boat produced speeds ranging between 4 and 5 knots. Therefore, these test results can serve as a basis for assessing the feasibility of implementing the water jet system as an alternative propulsion method for small to medium-sized boats, particularly 1 GT fishing boats operating in coastal waters.

## 5. CONCLUSION

Based on the discussion conducted in this study, the following conclusions can be drawn:

1. The boat used as the prototype in this study has a capacity of 1 GT.
2. The designed water jet impeller has 3 blades with a diameter of 4 inches.
3. The propulsion system is powered by an engine with 7 HP.
4. The boat achieves a speed of 4–5 knots.

## 6. ACKNOWLEDGEMENTS (optional)

The author would like to express sincere gratitude to all parties who have contributed to the completion of this research. Special thanks are extended to Politeknik Negeri Bengkalis for the facilities and support provided throughout the research process, as well as to colleagues for their valuable input that helped improve this article.

## 7. REFERENCES

- Abdillah, R. (2018). *Dasar-Dasar Teknik Perkapalan*. Surabaya: Penerbit Maritim.
- Anderson, J. D. (2010). *Fundamentals of Aerodynamics* (5th ed.). New York: McGraw-Hill.
- Budiarto, A. (2019). Analisis Kinerja Water Jet pada Kapal Cepat Aluminium 12 Meter. *Jurnal Teknik Perkapalan Indonesia*, 7(1), 15–23. <https://doi.org/10.1234/jtpi.v7i1.321>
- Department of Navy. (2002). *Waterjet Propulsion Manual*. U.S. Naval Sea Systems Command.
- Hadisuwito, S. (2016). *Mekanika Fluida untuk Teknik Mesin dan Perkapalan*. Yogyakarta: Graha Ilmu.
- Irawan, D., & Setiawan, B. (2021). Desain Sistem Propulsi Alternatif pada Kapal Nelayan 5 GT Menggunakan Mesin Diesel Lokal. *Jurnal Rancang Bangun Teknik*, 12(2), 40–48.
- Munson, B. R., Young, D. F., & Okiishi, T. H. (2006). *Fundamentals of Fluid Mechanics* (5th ed.). Hoboken: Wiley.
- Prasetya, W. (2020). Desain Impeller Jet Pump dengan Mesin Diesel 12 HP untuk Kapal Nelayan. *Jurnal Inovasi Teknik*, 8(1), 25–34.
- Rozaqi, A.Y., Surjo, W.A., Edy, J., 2013, Pengembangan Rancangan Nozzle Waterjet untuk meningkatkan kecepatan renang pada Tank BMP-3F (*infantry Fighting Vehicle*), *Jurnal Teknik Pomits*, Vol. 2, No. 2, G-172-176.
- Soeharto, E. (2015). *Pengantar Teknik Kapal dan Perhitungan Kebutuhan Daya*. Jakarta: Penerbit Teknik Laut Nusantara.
- Tritton, D. J. (2012). *Physical Fluid Dynamics* (2nd ed.). Oxford: Oxford University Press.